



92150475

DOGWASH SYSTEM

WITH 7.1kW WATER HEATER

OPERATING AND INSTRUCTION MANUAL



1

2



3

4

5

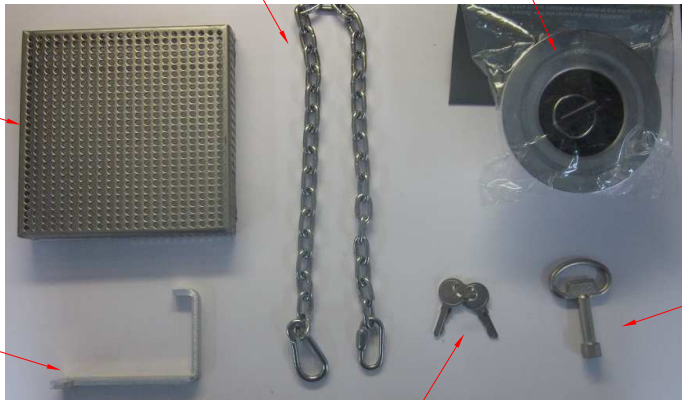

8

10

6

7

11

9

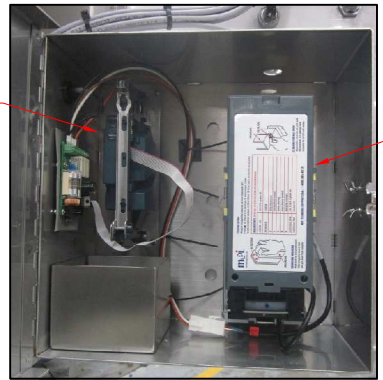

12

13



23

25

14

24

16

17

15

20

21

19

22

18

BILL OF MATERIAL

ITEM	DESCRIPTION	PART NO	QTY
1	Air Dryer Hose	92150629	1
2	Water Spray Nozzle and Hose	92150671	1
3	Flow Switch	92150668	1
4	Air Dryer	92150507	1
5	Pulse Counter	92151705	1
6	Dog Hair Grate	NA	1
7	Wash Bay Lifter Tool	NA	1
8	Wash Bay Dog Chain	92150642	2
9	Dogwash Keys	NA	5
10	Wash Bay Drain	NA	1
11	Electrical Enclosure Key	NA	1
12	Coin / Token Acceptor	92150591	1
13	Note Acceptor	92150350	1
14	Dosing Pump	92150916	4
15	Dosing Pump Suction Foot Filter	92150662	4
16	Y Strainer	92103900	1
17A	Pressure Reducing Valve	788439	1
17B	Pressure Gauge	92150649	1
18	Isolation Valve	92150529	1
19	V3 HWS Safety Valve - Solenoid Valve	286836	1
20	HWS - 7.1kW - 230VAC - 30A	92150351	1
21	Tempering Valve	92150659	1
22	Burkert 8400 Temperature Switch	436501	1
23	Dosing Pump Injection Nozzles	NA	4
24	V1 Disinfectant Valve - Solenoid Valve	125301	1
25	V2 Wash Valve - Solenoid Valve	286836	1
	24VDC Power Supply	92150149	1
	Controller	92160205	1
	Pushbuttons	92150515	8

OPTIONAL EXTRAS

ITEM	DESCRIPTION	PART NO	QTY
	Light Assembly	92150635	1
	Thermostat and Heater Kit	92186242	1
	Strainer / Drain Basket	92150637	1
	Nayax Card Reader	NA	1

Functional Description

The Electrical system in the Dog Wash uses proven components. All the component parts can be replaced.

The main components are:

1. PLC - Controller
2. Electrical Enclosure - Circuit Breakers, Relays and 24VDC Power Supply
3. Solenoid Valves
4. Hot Water System
5. Temperature Switch
6. Flow Switch
7. Air Dryer
8. The Coin/Token and Note Validator
9. Pushbuttons

The PLC accepts a pulse input on I0 (Dollar Counter) and starts to run the wash program after a minimum of \$10 is achieved. The push buttons which activate the wash options. Depending on which button is pressed will then operate the corresponding output of the PLC.

The LCD Text screen is a device that allows the user to monitor a wash process. The Unitronics Jazz is both the PLC and the LCD display.

Dog Wash Buttons Functionality

- **Shampoo:** Dispenses Shampoo Chemical via Shampoo Dosing Pump
- **Conditioner:** Dispenses Conditioner Chemical via Conditioner Dosing Pump
- **Flea Rinse:** Dispenses Flea Rinse Chemical via Flea Rinse Dosing Pump
- **Clean Rinse:** Clean Water only. No Chemical
- **Disinfectant:** Dispenses Disinfectant Chemical via Disinfectant Dosing Pump
- **Dry:** Low speed blow dry
- **Turbo Dry:** High speed blow dry
- **Pause:** for pausing time and functions (if fitted)

Steps for Cleaning Your Dog

1. Open door and put dog on the wash table.
2. Please secure the dog to the wash table with the chain and clip provided.
There are two clips one at either end of the wash table.
3. Insert coins, tokens or notes. The screen will count down coins until it amounts to the minimum amount to start a wash, pre-set at \$10.
4. Select wash options by pressing a button of your choice.
5. At any time during the sequence monies can be added to increase duration of wash
6. With 60 seconds remaining the beeper will sound every 10 seconds.
7. Once time has finished remove dog from Wash bay.

To select the wash options push the relevant button on the cabinet. Each button will illuminate when selected. The customer may change the wash options any number of times during the wash period. Only one function may run at a time.

Disinfectant Cycle

In the last minute of the wash sequence, a 10 seconds interval beeper will start, informing the users that there is one minute to go until wash cycle is over. During this time users may insert more money to increase the wash time.

Immediately after the wash cycle has timed out, the screen will prompt the user to **'Please Remove Your Loved One'**. Money is now no longer accepted. This Message will remain for 30 seconds until another message will notify the user that the system is **'Preparing for Disinfectant Cycle'**. The system will continuously beep for 15 seconds (1 second intervals) during this time. After that the disinfectant cycle will run, **'Disinfectant Cycle Running'** will be displayed. The disinfectant cycle will run continuously for 5 seconds, spraying Disinfectant chemical into the wash bay. The system will automatically reset once finished.

This can be de-activated if not required, please contact Washtec Service for more information.

Hot Water System (HWS)

To ensure that hot water is available at all times an electrical Instantaneous type system has been fitted. The unit feeds hot water to a tempering valve which has been set for a maximum operation temperature of 40°C. This is tested and set during build and testing however depending on each individual installation this may need further adjustment once the unit is installed onsite. Please refer to Hot Water troubleshooting.

For safety reasons an ON/OFF valve on the supply side controls the flow of incoming water to the HWS. The temperature of the incoming flow is monitored closely via a Burkert 8400 Temperature Switch. Apart from monitoring the temperature of the incoming water, the Switch is used as a safety device. The Burkert 8400 Temperature switch has a High and a Low Set point. The high set point is set at 48°C and the low set point is set at 40°C. This means that when the temperature of the incoming water flow reaches or exceeds the high set point value of 48°C , the Burkert ON/OFF valve will shut off, preventing any water going through. As a result the water in the line will cool down and the valve will open allowing for water to go through when the low set point of 40°C is achieved. Please note that the Burkert 8400 Temperature switch does not control the temperature, it is only a display and over-temperature safety switch.

Tempering Valve

The tempering valve mixes hot and cold water in order to maintain safe temperature. To check the correct temperature is achieved start the system and operate the trigger via the "Clean Rinse" function. Run this process for a period of one minute and check the outlet temperature via the digital display. If the temperature is outside the desired range remove the cap on the tempering valve and adjust accordingly, please refer to Tempering Valve Instructions supplied with dogwash for more information.

The Tempering Valve must have water connected to both Hot and Cold sides, if either one is not present water will not be outputted.

Coin / Token Operation

The coins are caught in a steel pot located underneath the electronic coin mechanism. The coin/note acceptor assembly has a complete locking system, isolating it from the electrical backplane cabinet and the chemical cabinet. Coins are recognised by the system as a 'Pulse Per Dollar' and any damaged or unrecognised coins are returned to the user via a coin return mechanism. To the coin acceptor is supplied to accept \$1 and \$2 coins only. Tokens can be programmed to be accepted and coins/tokens can be disabled. Please refer to instructions on side of coin acceptor.

Note Operation

The note reader will accept \$5, \$10, \$20 & \$50 notes and will store each note in the same steel pot where the coin acceptor is located. They are read as a 'Pulse Per Dollar' in the PLC and any damaged or unrecognised notes will be rejected back to the user.

Chemical Dosing Pumps

There are four diaphragm chemical dosing pumps:

- **Shampoo**
- **Conditioner**
- **Flea Rinse**
- **Disinfectant**

They are located underneath the main control cabinet and will require to have relevant chemical containers attached to the inlet side of the pumps.

The dosing quantity can be adjusted via the % control dial on the front of the pumps. Please adjust while the pump is operating to ensure correct dosing quantity is acquired. Best dosing results are achieved when the dosing pumps are in their most clockwise position (maximum dosing).

It should also be noted that the dosing pumps only operate when there is water flow (Spray nozzle in use). This design prevents damage to the dosing pumps but more importantly prevents any chemical being wasted. This is achieved via a flow switch mounted closely near the wash nozzle outlet which switches Relay R8 which is a master control relay for all four dosing pumps.

Pressure Reducing Valve

All units are fitted with a Y strainer and a pressure reducing valve. Before connecting the system to mains water it is advisable that all lines are flushed from any debris to prevent clogging of the Y strainer. Once connected the pressure reducing valve is pre-set to 6 bar pressure. There is a gauge provided on the PRV to indicate outlet pressure.

Pressure must not exceed 6 bar at any stage. It is advisable to remove basket from strainer periodically for cleaning purposes.

Warning Do not run the system without the basket in Y strainer

Installation

Installation should be carried out by qualified personnel.

Installation should meet all the necessary electrical and plumbing standards relevant to the location in which the unit is installed.

Mains water is required before electrical connection can be switched on

TECHNICAL DATA

ELECTRICAL	
SUPPLY VOLTAGE	230VAC - 50Hz
MAX POWER	7.2kW
MAX CURRENT	32A
WATER	
WATER SUPPLY FITTING	1/2'BSP
WATER SUPPLY PRESSURE	3-10 bar
OPERATING PRESSURE - PRV	4-6 bar
FLOW RATE	6-8 L/min
DRAINAGE CONNECTION	50mm
CONSTRUCTION	
HEIGHT	1800mm
WIDTH	2062mm
DEPTH	600mm
MATERIAL	SS 304
WEIGHT	230kg

The Dog Wash comes fully assembled. There are 6 adjustable feet on the unit, in order to provide balance and support to the unit when in position.

The machine needs to be level on all planes to prevent for correct operation.

Prime Pumps

In order to prime the pumps place both the inlet tube (foot filter with SS weight) and the prime tube into the corresponding solution.

The pump must be operating in order to prime, to do this insert coins and press the relevant button in accordance with the pump e.g. Shampoo button to operate the Shampoo pump.

With the pump operating turn the Prime Dial anti-clockwise all the way to allow the pump to prime. The solution should be visible moving through the clear tube inlet. In the case of difficulties, use a normal syringe to suck liquid through the prime tube. Try to keep the suction and discharge hose as straight as possible.

Once the solution has entered the pump it will then start exiting via the Prime Tube. When the solution is visible in the prime tube the Prime Dial can then be closed by turning it clockwise all the way.

The pump will then be primed and solution should be coming out of the spray gun.

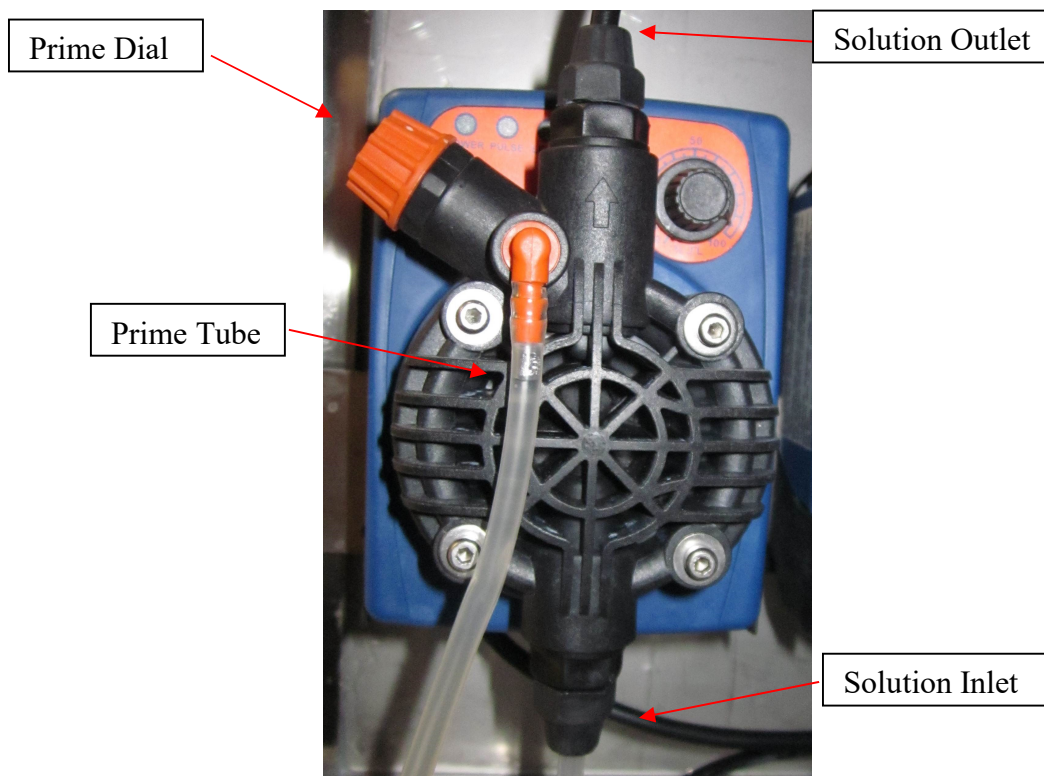

1. Operators Daily Check

- Check that the chemicals have a level to maintain the use of the unit on the day
- Ensure the ends of the chemical tubes are fully submerged well in the chemical container to prevent air bubbles in the dosing lines.
- Fully extend the dryer hose and check for kinks, splits, twists, knots and any general wear and tear
- Inspect the water gun for damage; ensure the water flows freely from the gun when the trigger is pressed and that it shuts off completely when the trigger is released
- Inspect the Coin Validator/Note Acceptor for jammed coins/notes or damage.
- Check for any signs of a water leak or blocked drain

2. Regular Service/Maintenance Check

- Check the operation of the chemical pump, remember the pump will only turn on when flow is present.
- Regularly disinfect wash and rinse down
- Check for build-up of hair in wash bay (figure 2).
- Clean the wash bay of any hair that has built up around the drain cover (figure 3). To get to the drain cover lift the blue floor using the wash bay tool (figure 4). Using the clean rinse cycle wash down the wash bay of any hair. Remove hair from drain cover and disinfect using the disinfectant cycle before re-installing the blue flooring (figure 5).



(Figure 2)

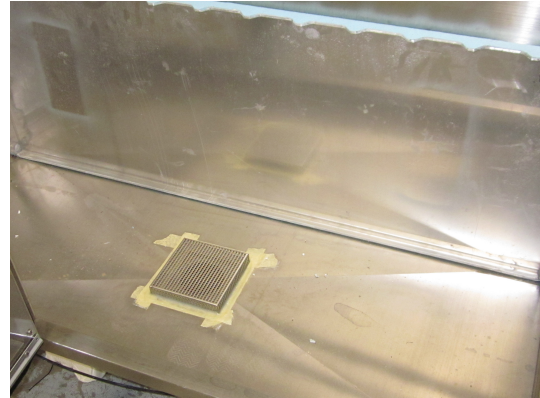

(Figure 3)

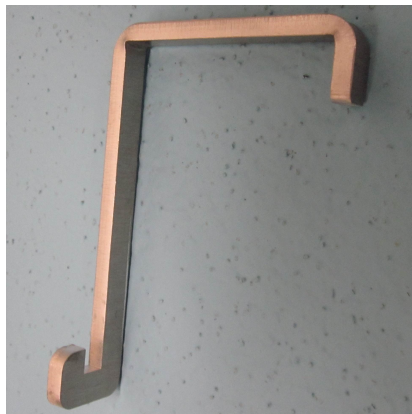

(Figure 4)

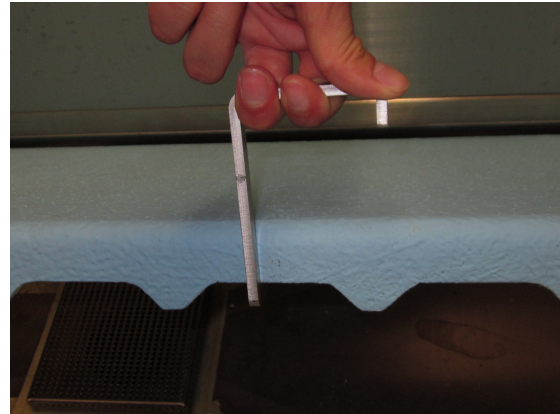

(Figure 5)

3. 6 Month Service

- Blow Dry Filter Service. To clean out the dryer, undo the cap at the bottom of the dryer (figure 6). Remove the vent at the bottom and clean it under a tap (figure 7). Once clean leave filter to dry before re-installing.

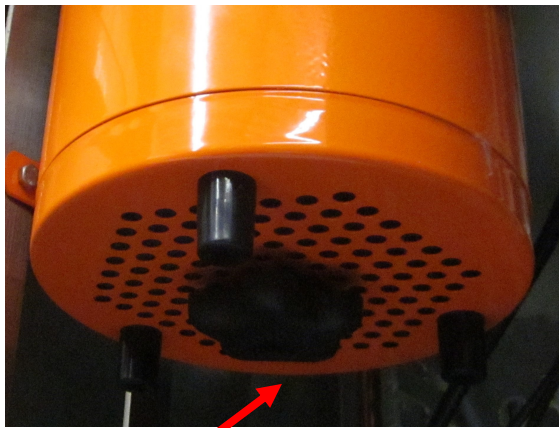

(Figure 6)

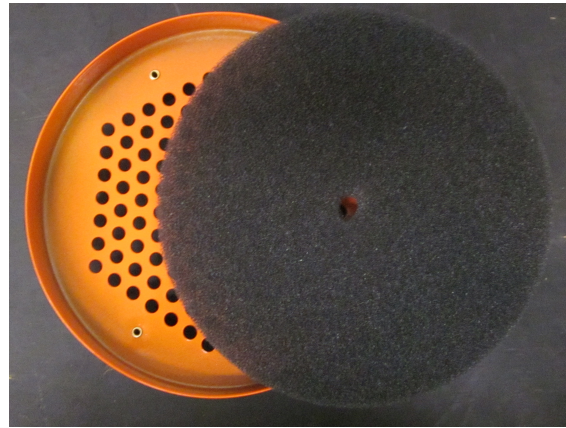

(Figure 7)

- Water Supply Service. You will need to clean out the Y strainer for any foreign objects. This can be found near the water inlet (figure 8). Ensure that the main supply of water is off, remove the nut of the Y strainer (figure 9), clean out the strainer then re-install.



(Figure 8)

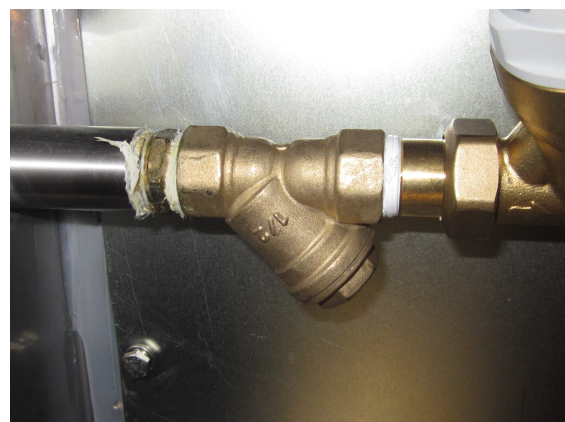

(Figure 9)

Troubleshooting

T1.1 Machine fails to operate after coin/note insertion

1. Check that the electrical supply to the machine is ON. Check Circuit Breakers are on
2. Check the coin/note travels freely through the coin/note mechanism.
3. Check the operation of the coin/note mechanism. There should only be a green light on the coin acceptor and the note acceptor lights should illuminate green on the front note entry area.

T1.2 Machine Runs Continuously

1. Open the door and check for coins/notes caught up in the mechanism.
2. Before attempting to clear any obstructions, isolate the power.
3. Check status of PLC display. Reset Power

T1.3 Machine not dispensing water/low water pressure

1. Check that the water supply is turned ON fully.
2. Remove hoses from quick release fittings and check for water flow.
3. If there is flow, check for blockages in the hoses or spray gun.
4. Check the hoses and fittings for leaks.
5. Check Solenoid Valves 2 and 3.
 - V2 should operate during any wash cycle involving water.
 - V3 should always be on. If not check 8400 Temp Switch Red LED is on, if not refer to T1.5
6. Make sure no other sources of water are being used on the same water circuit that maybe limiting the amount of water to the Dogwash.

T1.4 Machine not dispensing chemicals

1. Check the chemical storage levels. Check suction tubes are fully submerged in chemical storage.
2. Check that the appropriate dosing pump is operating correctly. Start system and select corresponding pushbutton. Flow must be present for dosing pumps to operate.
Dosing Pump 1 is Shampoo
Dosing Pump 2 is Conditioner
Dosing Pump 3 is Flea Rinse
Dosing Pump 4 is Disinfectant
3. Check for blockages, kinks and air locks in the chemical tubing.
4. Check for blockages in the chemical inlet manifold.
5. Check operation of the flow switch located near the water nozzle outlet. When flow is present Relay R8 will be on inside electrical enclosure. If it does not turn on, adjustment to the flow switch may be necessary. Please refer to flow switch manual provide with Dogwash for more information.

T1.5 Machine not dispensing Hot Water or Too Cold Water

1. Check HWS Circuit Breaker is on.
2. Check Solenoid Valve V3, this is a Safety ON/OFF valve. It is controlled by the Burkert 8400 Temperature Switch. The Red LED needs to be on for V3 to be on. If the LED is off, check the temperature via the 8400's display. If the temperature has exceeded 48°C V3 will switch off and won't switch back on until the water has cooled to below 40°C. This will take a couple of minutes
3. Check your water supply. If it is too cold (below 10°C) the HWS may have trouble heating water. The HWS is instantaneous not storage therefore it may take a short period of time before hot water is dispensed. The HWS will only heat the below temperatures above the water inlet temperatures
Flow – 6L/min Temp Increase of 16°C
Flow – 8L/min Temp Increase of 13°C
4. Check the Tempering Valve. The tempering valve is used to regulate and set the temperature of mixed hot and cold water supply. Due to the unique design of the cap, the temperature setting can be adjusted by removing the cap from the valve body and reversing the cap onto the temperature adjustment spindle.

Temperature adjustment

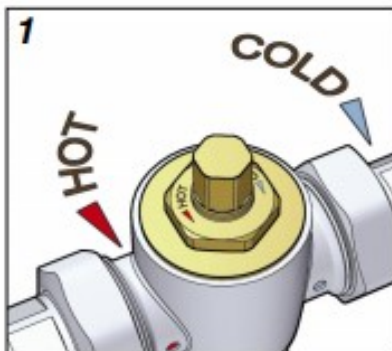

◀ Direction of temperature adjustment

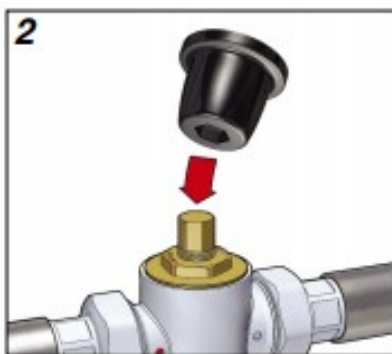

◀ Fitting cap for temperature adjustment

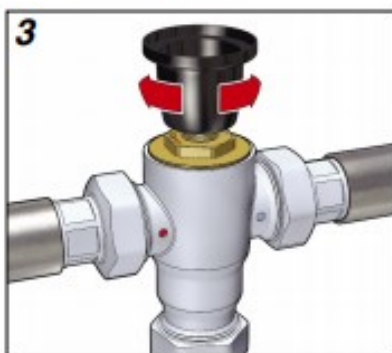

◀ Temperature adjustment cap in place

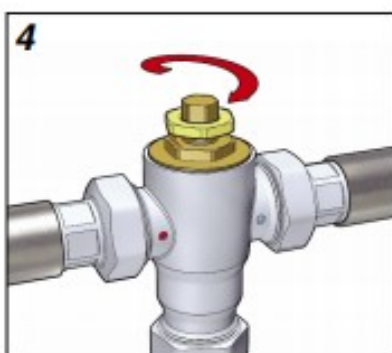

◀ Lock temperature adjustment spindle with locking nut

T1.6 Machine dispensing Too Hot Water

1. Ensure water to the Dogwash does not exceed 20°C
2. Check the Tempering Valve and adjust as per T1.5 - 4

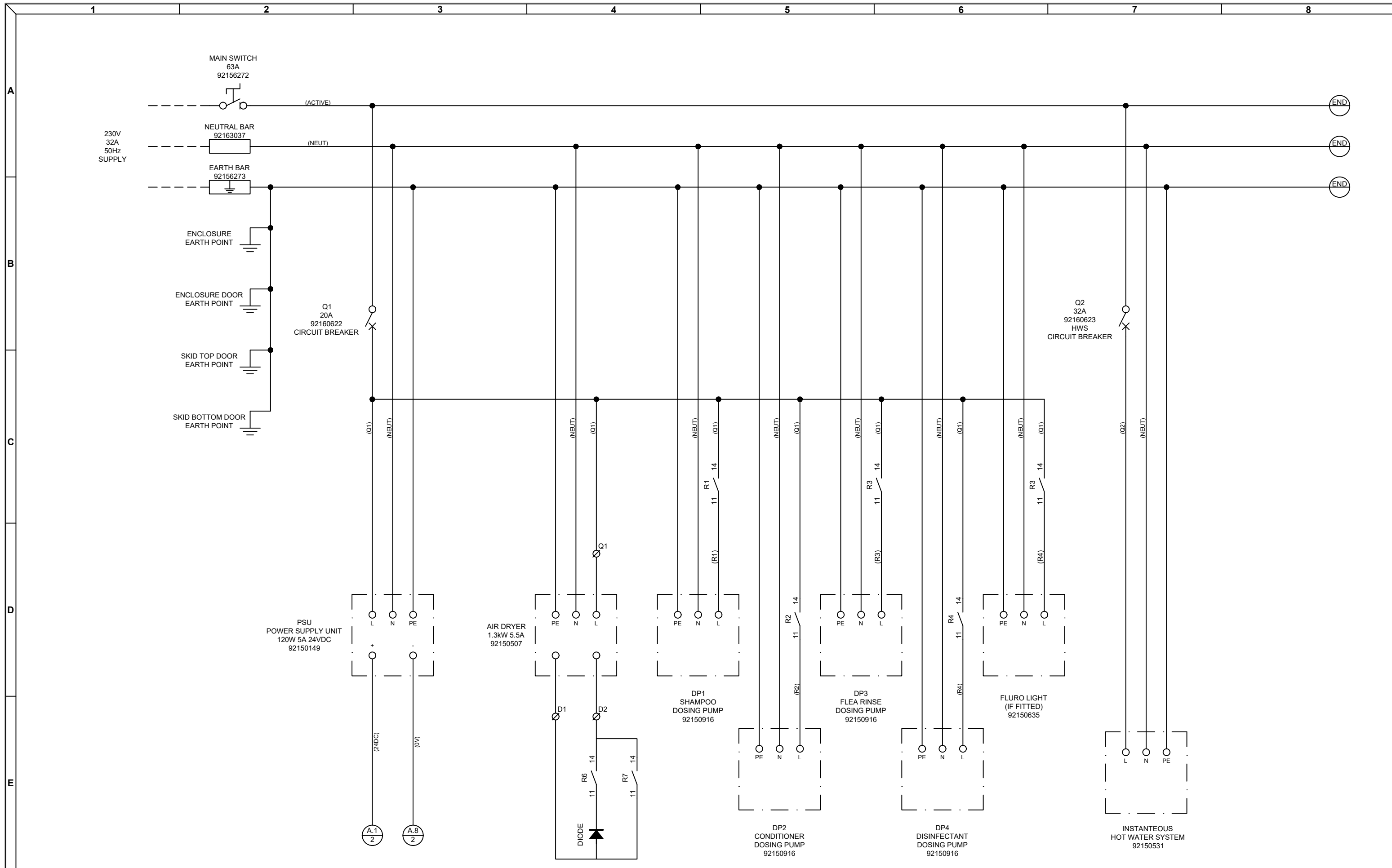

REV	DESCRIPTION	DRAWN BY	CHECKED BY	DATE
2	UPDATED ELECTRICAL DESIGN - CHANGED NOTE ACCEPTOR WIRING	J.SCHRODER	A.FERRARO	11/08/2020
1	UPDATED ELECTRICAL DESIGN - CHANGED PLC CABLE	J.SCHRODER	N.CHYMIK	24/11/2017
0	UPDATED ELECTRICAL DESIGN - ADDED EARTH + NEUTRAL BARS	J.SCHRODER	N.CHYMIK	20/10/2011

THIS DRAWING IS THE
SUBJECT OF COPYRIGHT
AND MUST NOT BE COPIED
OR OTHERWISE USED
WITHOUT THE EXPRESS
AUTHORITY OF BURKERT
CONTROMATIC AUSTRALIA



BURKERT CONTROMATIC AUSTRALIA PTY LTD
 SYDNEY: 15 COLUMBIA WAY, NORWEST BUSINESS PARK, BALUKHAM HILLS, NSW, 2153
 MELBOURNE: LINNAPARK BUILDING 4, 195 WELLINGTON RD, CLAYTON, VIC, 3168
 BRISBANE: UNIT 1, 88 BRANDL ST, BRISBANE TECHNOLOGY PARK, EIGHT MILE PLAINS, QLD, 4113
 PERTH: UNIT 8, 1st FLOOR 85 REID PROMENADE, JOONDALUP, WA, 6027
 ADELAIDE: INNOVATION HOUSE, FIRST AVE, MAWSON LAKES, SA, 5095

CUSTOMER: WASHTEC			
PROJECT: DOGWASH SYSTEM MK3.1			
TITLE: ELECTRICAL WIRING DIAGRAM			
DRAWING NUMBER: 92150475-ELE-02			
SCALE: N.T.S	JOB NUMBER: N/A	SHOP ORDER NUMBER: 92150475	SHEET NUMBER: 01 OF 06 SHEETS

SIZE
A3

REVISION
2

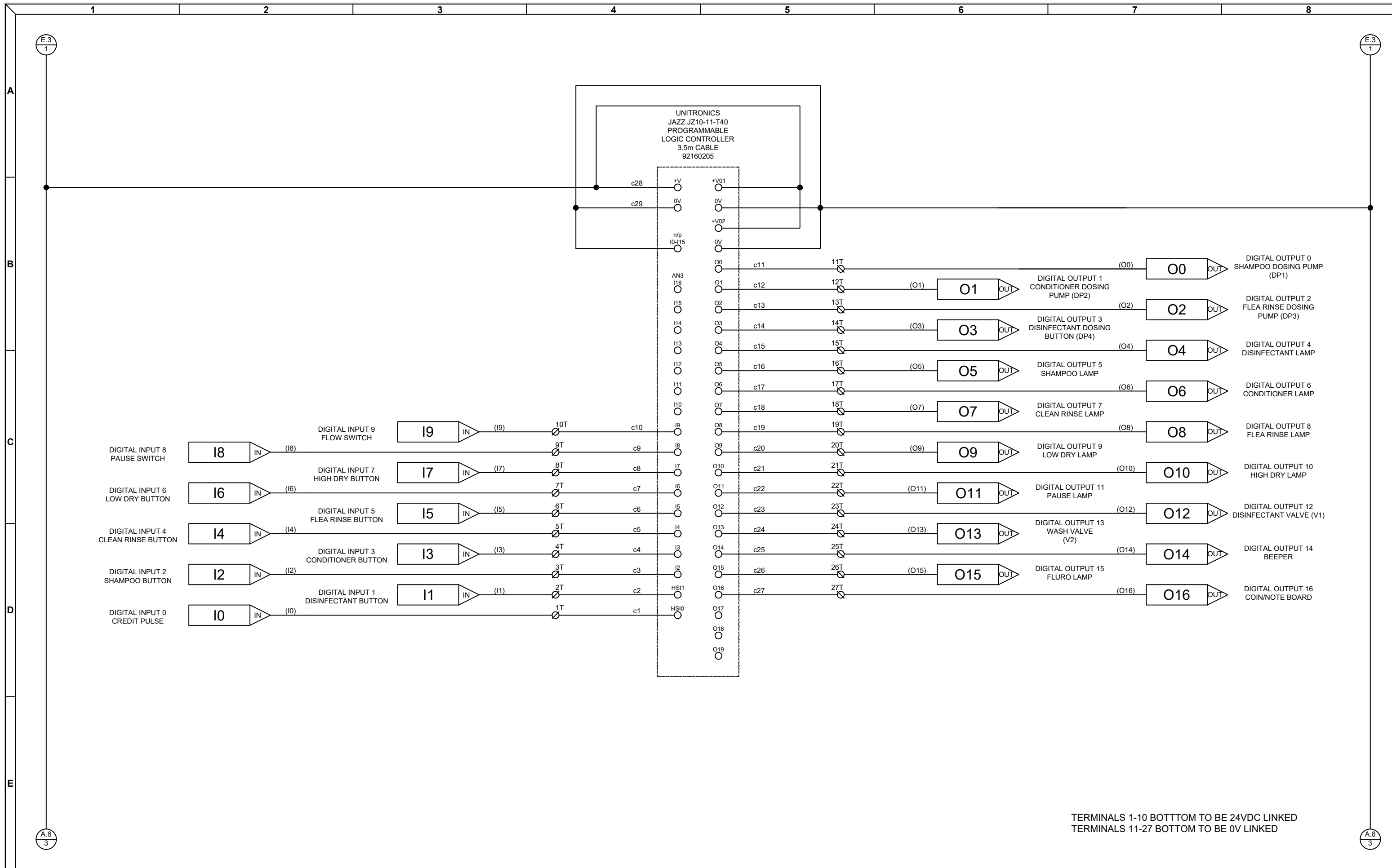

TERMINALS 1-10 BOTTOM TO BE 24VDC LINKED
TERMINALS 11-27 BOTTOM TO BE 0V LINKED

REV	DESCRIPTION	DRAWN BY	CHECKED BY	DATE
2	UPDATED ELECTRICAL DESIGN - CHANGED NOTE ACCEPTOR WIRING	J.SCHRODER	A.FERRARO	11/08/2020
1	UPDATED ELECTRICAL DESIGN - CHANGED PLC CABLE	J.SCHRODER	N.CHYMIK	24/11/2017
0	UPDATED ELECTRICAL DESIGN - ADDED EARTH + NEUTRAL BARS	J.SCHRODER	N.CHYMIK	20/10/2011

THIS DRAWING IS THE
SUBJECT OF COPYRIGHT
AND MUST NOT BE COPIED
OR OTHERWISE USED
WITHOUT THE EXPRESS
AUTHORITY OF BURKERT
CONTROMATIC AUSTRALIA



BURKERT CONTROMATIC AUSTRALIA PTY LTD
SYDNEY: 15 COLUMBIA WAY, NORWEST BUSINESS PARK, BALKHAM HILLS, NSW, 2153
MELBOURNE: LINBARK BUILDING 4, 195 WELLINGTON RD. CLAYTON, VIC, 3168
BRISBANE: UNIT 5, 88 BRANDL ST, BRISBANE TECHNOLOGY PARK, EIGHT MILE PLAINS, QLD, 4113
PERTH: UNIT 8, 14 FLOOR 85 REID PROMENADE, JOONDALLUP, WA, 6027
ADELAIDE: INNOVATION HOUSE, FIRST AVE, MAWSON LAKES, SA, 5095

CUSTOMER: WASHTEC			
PROJECT: DOGWASH SYSTEM MK3.1			
TITLE: ELECTRICAL WIRING DIAGRAM			
DRAWING NUMBER: 92150475-ELE-02			
SCALE: N.T.S	JOB NUMBER: N/A	SHOP ORDER NUMBER: 92150475	SHEET NUMBER: 02 OF 06 SHEETS

SIZE: A3
REVISION: 2

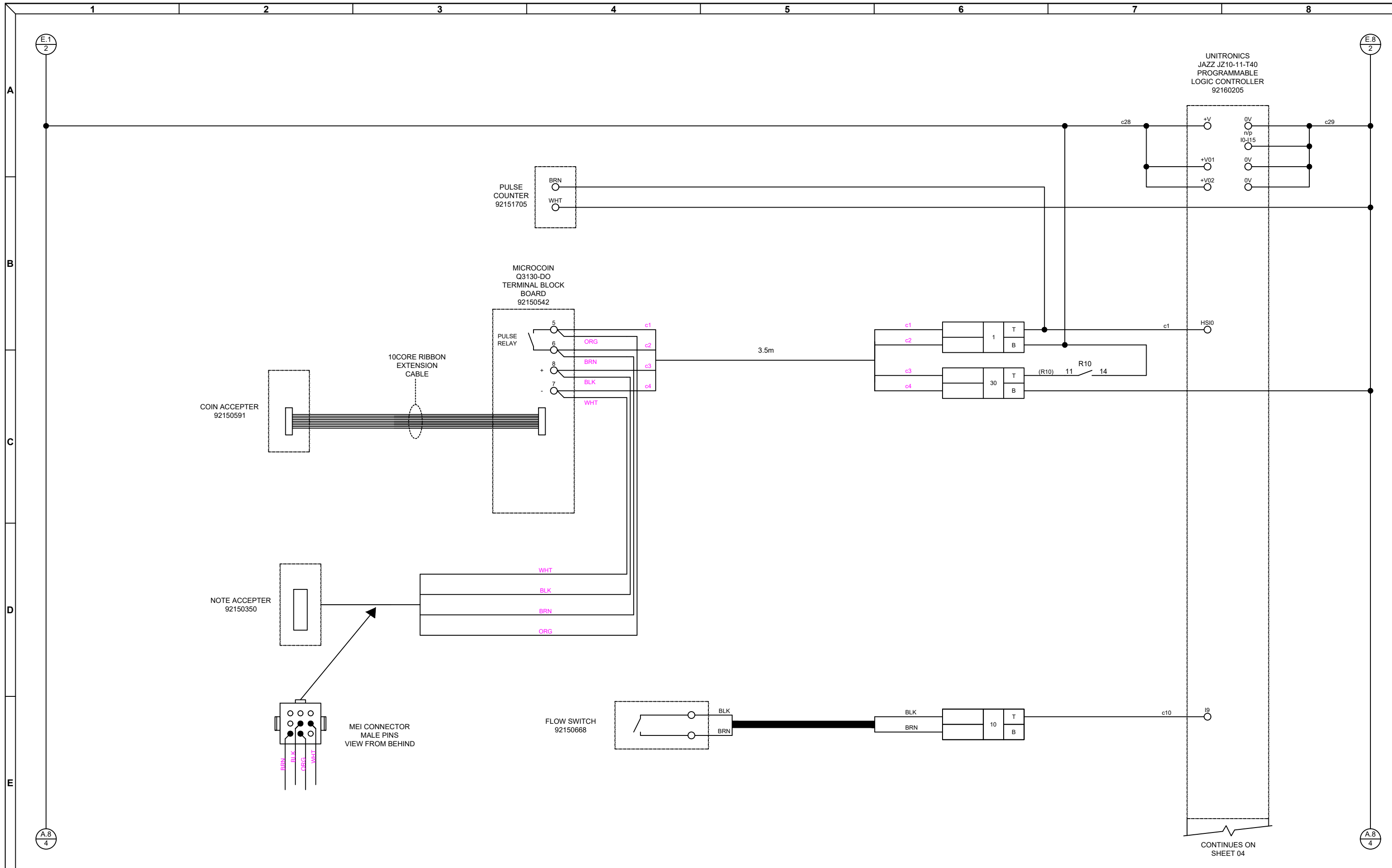

REV	DESCRIPTION	DRAWN BY	CHECKED BY	DATE
2	UPDATED ELECTRICAL DESIGN - CHANGED NOTE ACCEPTOR WIRING	J.SCHRODER	A.FERRARO	11/08/2020
1	UPDATED ELECTRICAL DESIGN - CHANGED PLC CABLE	J.SCHRODER	N.CHYMIK	24/11/2017
0	UPDATED ELECTRICAL DESIGN - ADDED EARTH + NEUTRAL BARS	J.SCHRODER	N.CHYMIK	20/10/2011

THIS DRAWING IS THE SUBJECT OF COPYRIGHT AND MUST NOT BE COPIED OR OTHERWISE USED WITHOUT THE EXPRESS AUTHORITY OF BURKERT CONTROMATIC AUSTRALIA

burkert
FLUID CONTROL SYSTEMS

BURKERT CONTROMATIC AUSTRALIA PTY LTD
 SYDNEY: 15 COLUMBIA WAY, NORWEST BUSINESS PARK, BALKHAM HILLS, NSW, 2153
 MELBOURNE: LINAPARK BUILDING 4, 195 WELLINGTON RD, CLAYTON, VIC, 3168
 BRISBANE: UNIT 5, 88 BRANDL ST, BRISBANE TECHNOLOGY PARK, EIGHT MILE PLAINS, QLD, 4113
 PERTH: UNIT 8, 14 FLOOR 85 REID PROMENADE, JOONDALLUP, WA, 6027
 ADELAIDE: INNOVATION HOUSE, FIRST AVE, MAWSON LAKES, SA, 5095

Phone: 1300 888 868 Fax: 1300 888 076 www.burkert.com.au

CUSTOMER: WASHTEC				SIZE: A3
PROJECT: DOGWASH SYSTEM MK3.1				REVISION: 2
TITLE: ELECTRICAL WIRING DIAGRAM				
DRAWING NUMBER: 92150475-ELE-02				SHEETS: 03 OF 06
SCALE: N.T.S	JOB NUMBER: N/A	SHOP ORDER NUMBER: 92150475	SHEET NUMBER: 03 OF 06	
SHEETS: 03 OF 06				

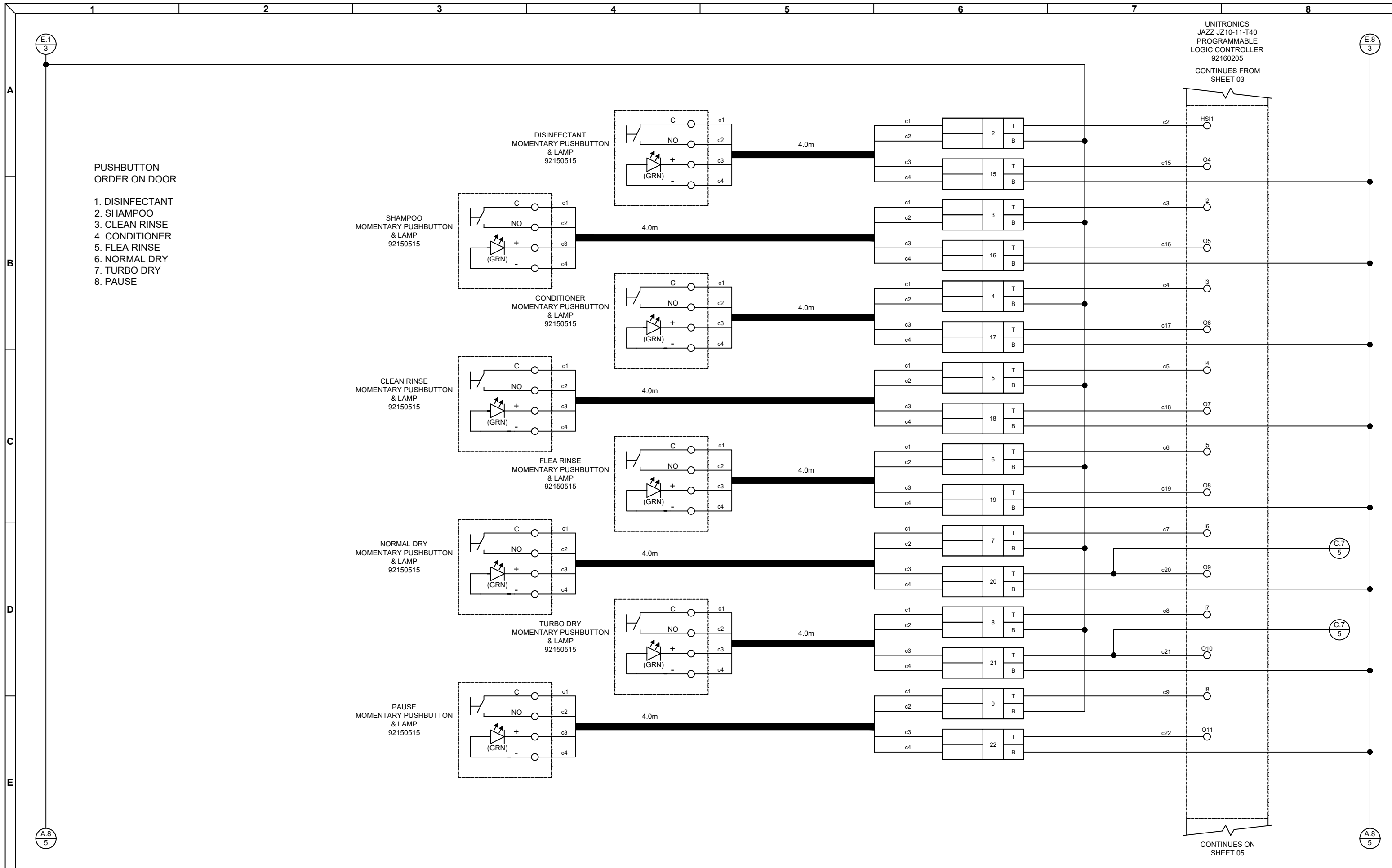

PUSHBUTTON ORDER ON DOOR

1. DISINFECTANT
2. SHAMPOO
3. CLEAN RINSE
4. CONDITIONER
5. FLEA RINSE
6. NORMAL DRY
7. TURBO DRY
8. PAUSE

UNITRONICS
JAZZ JZ10-11-T40
PROGRAMMABLE
LOGIC CONTROLLER
92160205
CONTINUES FROM
SHEET 03

CONTINUES ON
SHEET 05

REV	DESCRIPTION	DRAWN BY	CHECKED BY	DATE
2	UPDATED ELECTRICAL DESIGN - CHANGED NOTE ACCEPTOR WIRING	J.SCHRODER	A.FERRARO	11/08/2020
1	UPDATED ELECTRICAL DESIGN - CHANGED PLC CABLE	J.SCHRODER	N.CHYMIK	24/11/2017
0	UPDATED ELECTRICAL DESIGN - ADDED EARTH + NEUTRAL BARS	J.SCHRODER	N.CHYMIK	20/10/2011

THIS DRAWING IS THE
SUBJECT OF COPYRIGHT
AND MUST NOT BE COPIED
OR OTHERWISE USED
WITHOUT THE EXPRESS
AUTHORITY OF BURKERT
CONTROMATIC AUSTRALIA



BURKERT CONTROMATIC AUSTRALIA PTY LTD
SYDNEY: 15 COLUMBIA WAY, NORWEST BUSINESS PARK, Baulkham Hills, NSW, 2153
MELBOURNE: UNIPARK BUILDING 4, 195 WELLINGTON RD, CLAYTON, VIC, 3168
BRISBANE: UNIT 8, 1st FLOOR 85 REID PROMENADE, JOONDALLUP, WA, 6027
PERTH: UNIT 8, 1st FLOOR 85 REID PROMENADE, JOONDALLUP, WA, 6027
ADELAIDE: INNOVATION HOUSE, FIRST AVE, MAWSON LAKES, SA, 5095

CUSTOMER: WASHTEC			
PROJECT: DOGWASH SYSTEM MK3.1			
TITLE: ELECTRICAL WIRING DIAGRAM			
DRAWING NUMBER: 92150475-ELE-02			
SCALE: N.T.S	JOB NUMBER: N/A	SHOP ORDER NUMBER: 92150475	SHEET NUMBER: 04 OF 06 SHEETS

SIZE
A3
REVISION
2

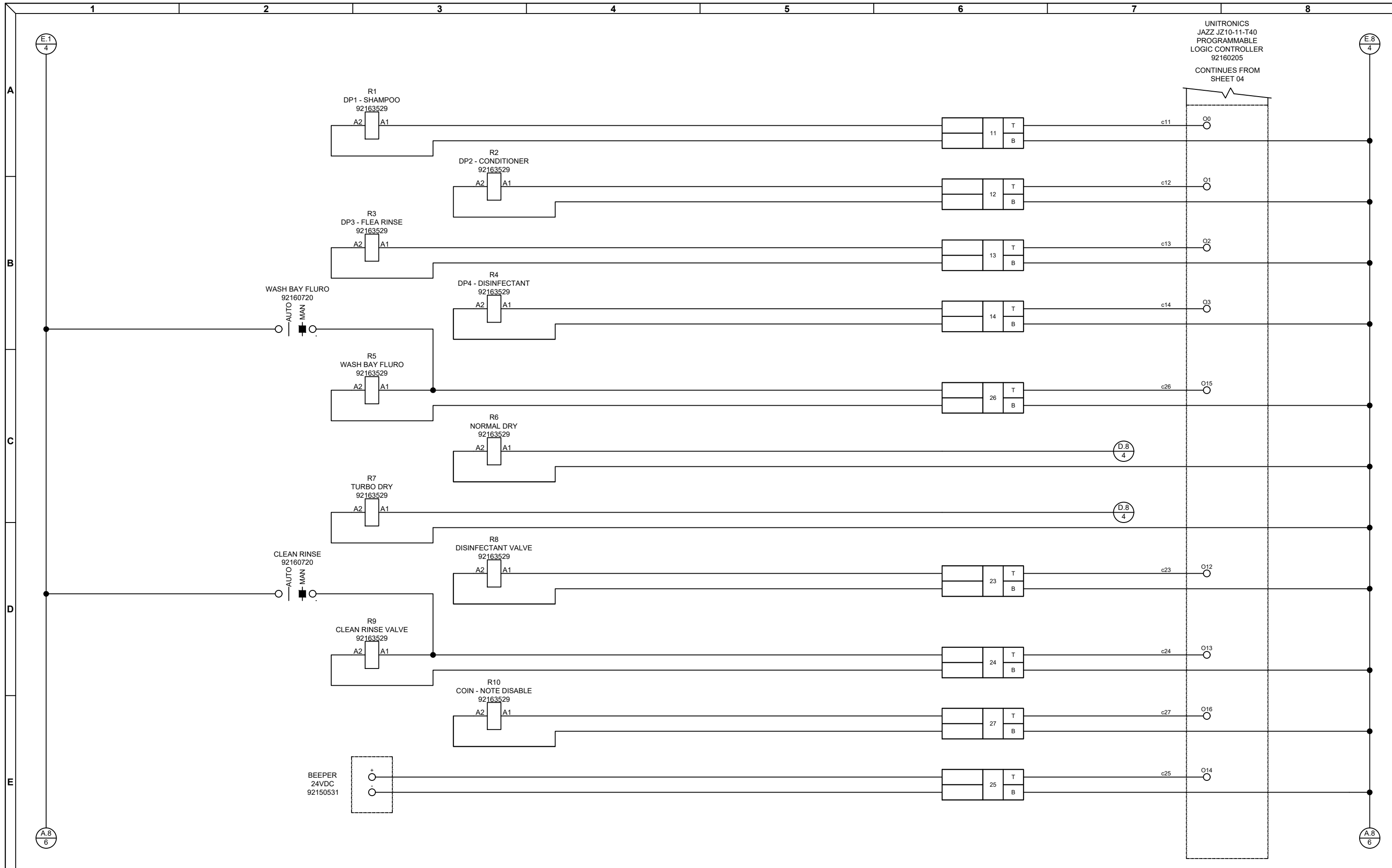

UNITRONICS
JAZZ JZ10-11-T40
PROGRAMMABLE
LOGIC CONTROLLER
92160205
CONTINUES FROM
SHEET 04

REV	DESCRIPTION	DRAWN BY	CHECKED BY	DATE
2	UPDATED ELECTRICAL DESIGN - CHANGED NOTE ACCEPTOR WIRING	J.SCHRODER	A.FERRARO	11/08/2020
1	UPDATED ELECTRICAL DESIGN - CHANGED PLC CABLE	J.SCHRODER	N.CHYMIK	24/11/2017
0	UPDATED ELECTRICAL DESIGN - ADDED EARTH + NEUTRAL BARS	J.SCHRODER	N.CHYMIK	20/10/2011

THIS DRAWING IS THE
SUBJECT OF COPYRIGHT
AND MUST NOT BE COPIED
OR OTHERWISE USED
WITHOUT THE EXPRESS
AUTHORITY OF BURKERT
CONTROMATIC AUSTRALIA



BURKERT CONTROMATIC AUSTRALIA PTY LTD
SYDNEY: 15 COLUMBIA WAY, NORWEST BUSINESS PARK, BULKHAM HILLS, NSW, 2153
MELBOURNE: UNIPARK BUILDING 4, 195 WELLINGTON RD, CLAYTON, VIC, 3168
BRISBANE: UNIT 8, 1st FLOOR 85 REID PROMENADE, JOONDALUP, WA, 6027
PERTH: UNIT 8, 1st FLOOR 85 REID PROMENADE, JOONDALUP, WA, 6027
ADELAIDE: INNOVATION HOUSE, FIRST AVE, MAWSON LAKES, SA, 5095

CUSTOMER: WASHTEC			
PROJECT: DOGWASH SYSTEM MK3.1			
TITLE: ELECTRICAL WIRING DIAGRAM			
DRAWING NUMBER: 92150475-ELE-02			
SCALE: N.T.S	JOB NUMBER: N/A	SHOP ORDER NUMBER: 92150475	SHEET NUMBER: 05 OF 06

SIZE
A3

REVISION
2

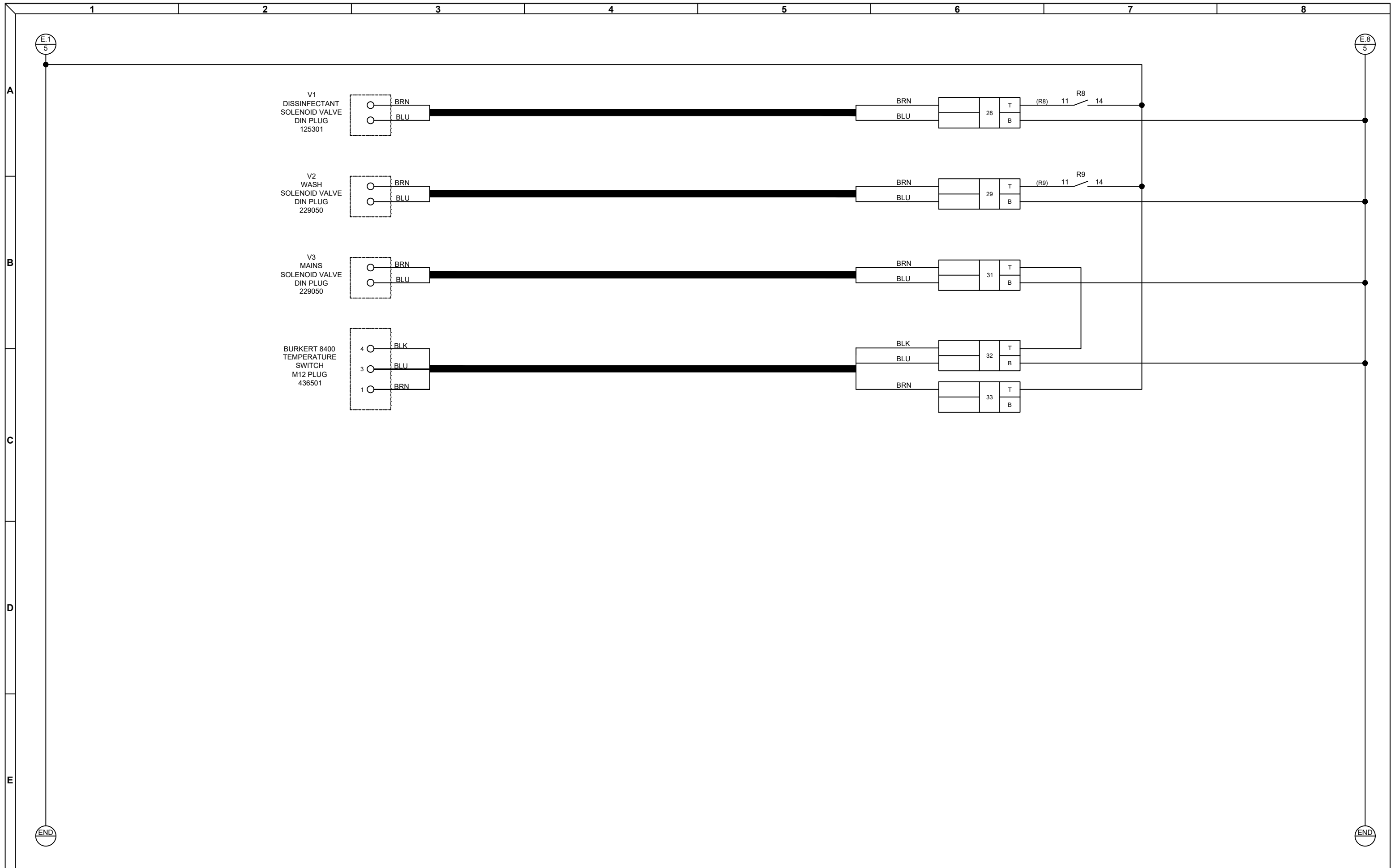

REV	DESCRIPTION	DRAWN BY	CHECKED BY	DATE
2	UPDATED ELECTRICAL DESIGN - CHANGED NOTE ACCEPTOR WIRING	J.SCHRODER	A.FERRARO	11/08/2020
1	UPDATED ELECTRICAL DESIGN - CHANGED PLC CABLE	J.SCHRODER	N.CHYMIK	24/11/2017
0	UPDATED ELECTRICAL DESIGN - ADDED EARTH + NEUTRAL BARS	J.SCHRODER	N.CHYMIK	20/10/2011

THIS DRAWING IS THE
SUBJECT OF COPYRIGHT
AND MUST NOT BE COPIED
OR OTHERWISE USED
WITHOUT THE EXPRESS
AUTHORITY OF BURKERT
CONTROMATIC AUSTRALIA



BURKERT CONTROMATIC AUSTRALIA PTY LTD
 SYDNEY: 15 COLUMBIA WAY, NORWEST BUSINESS PARK, BALKHAM HILLS, NSW, 2159
 MELBOURNE: UNIPARK BUILDING 4, 195 WELLINGTON RD, CLAYTON, VIC, 3168
 BRISBANE: UNIT 5, 88 BRANDL ST, BRISBANE TECHNOLOGY PARK, EIGHT MILE PLANS, QLD, 4113
 PERTH: UNIT 8, 14 FLOOR 85 REID PROMENADE, JOONDALLUP, WA, 6027
 ADELAIDE: INNOVATION HOUSE, FIRST AVE, MAWSON LAKES, SA, 5095

CUSTOMER: WASHTEC			
PROJECT: DOGWASH SYSTEM MK3.1			
TITLE: ELECTRICAL WIRING DIAGRAM			
DRAWING NUMBER: 92150475-ELE-02			
SCALE: N.T.S	JOB NUMBER: N/A	SHOP ORDER NUMBER: 92150475	SHEET NUMBER: 06 OF 06 SHEETS

SIZE: A3
REVISION: 2

CK-DOGWASH MK3.1 - I/O LIST

I/O TYPE/NUMBER	PLC ADDRESS	DESCRIPTION
AI 00	AN0	
AI 01	AN1	
AI 02	AN2	
AI 03	AN3	
DI 00	HSI0	Credit Pulse
DI 01	HSI1	Disinfectant Button
DI 02	I2	Shampoo Button
DI 03	I3	Conditioner Button
DI 04	I4	Clean Rinse Button
DI 05	I5	Flea Rinse Button
DI 06	I6	Low Dry Button
DI 07	I7	High Dry Button
DI 08	I8	Pause Button
DI 09	I9	Flow Switch
DI 10	I10	
DI 11	I11	
DI 12	I12	
DI 13	I13	
DI 14	I14	
DI 15	I15	
DO 00	O0	Shampoo Dosing Pump (DP1)
DO 01	O1	Conditioner Dosing Pump (DP2)
DO 02	O2	Flea Rinse Dosing Pump (DP3)
DO 03	O3	Disinfectant Dosing Pump (DP4)
DO 04	O4	Disinfectant Lamp
DO 05	O5	Shampoo Lamp
DO 06	O6	Conditioner Lamp
DO 07	O7	Clean Rinse Lamp
DO 08	O8	Flea Rinse Lamp
DO 09	O9	Low Dry Lamp
DO 10	O10	High Dry Lamp
DO 11	O11	Pause Lamp
DO 12	O12	Disinfectant Valve (V1)
DO 13	O13	Wash Valve (V2)
DO 14	O14	Beeper
DO 15	O15	Fluro Light
DO 16	O16	Coin/Note Board
DO 17	O17	
DO 18	O18	
DO 19	O19	

Dogwash Jazz Configuration Code

Each Dogwash PLC will have an individual code corresponding with the program settings. This code will be labelled on the back of the Jazz and recorded down in the Configuration Details spreadsheet and checksheet.

The Code is an 11 stage number system. Each stage is for each configuration setting and is in the following order:

1. Minimum Start Credit: 00
2. Seconds Per Credit: 000
3. Countdown Multiplier: 00
4. Remove Dog Timer: 00
5. Prepare Disinfectant Timer: 00
6. Disinfectant Cycle Run Timer: 00
7. Fluro Post Cycle On Time: 000
8. Minimum Start Shown On Display: 00
9. Beep Will Start When Time: 00
10. Beeper On Time: 00
11. Beeper Off Time: 00

Example:

10-060-01-15-10-05-180-10-60-2-11

This will be the most common code.

- \$10 Start
- 60 seconds per dollar
- Multiplier of 1
- 15 seconds of remove dog display
- 10 seconds prepare for disinfectant alarm
- 5 seconds disinfectant cycle
- 3 minutes post cycle fluro light
- \$10 Display
- Starts beeper with 1 minute left
- Beeps for 2 seconds
- Beeps in 11 second intervals

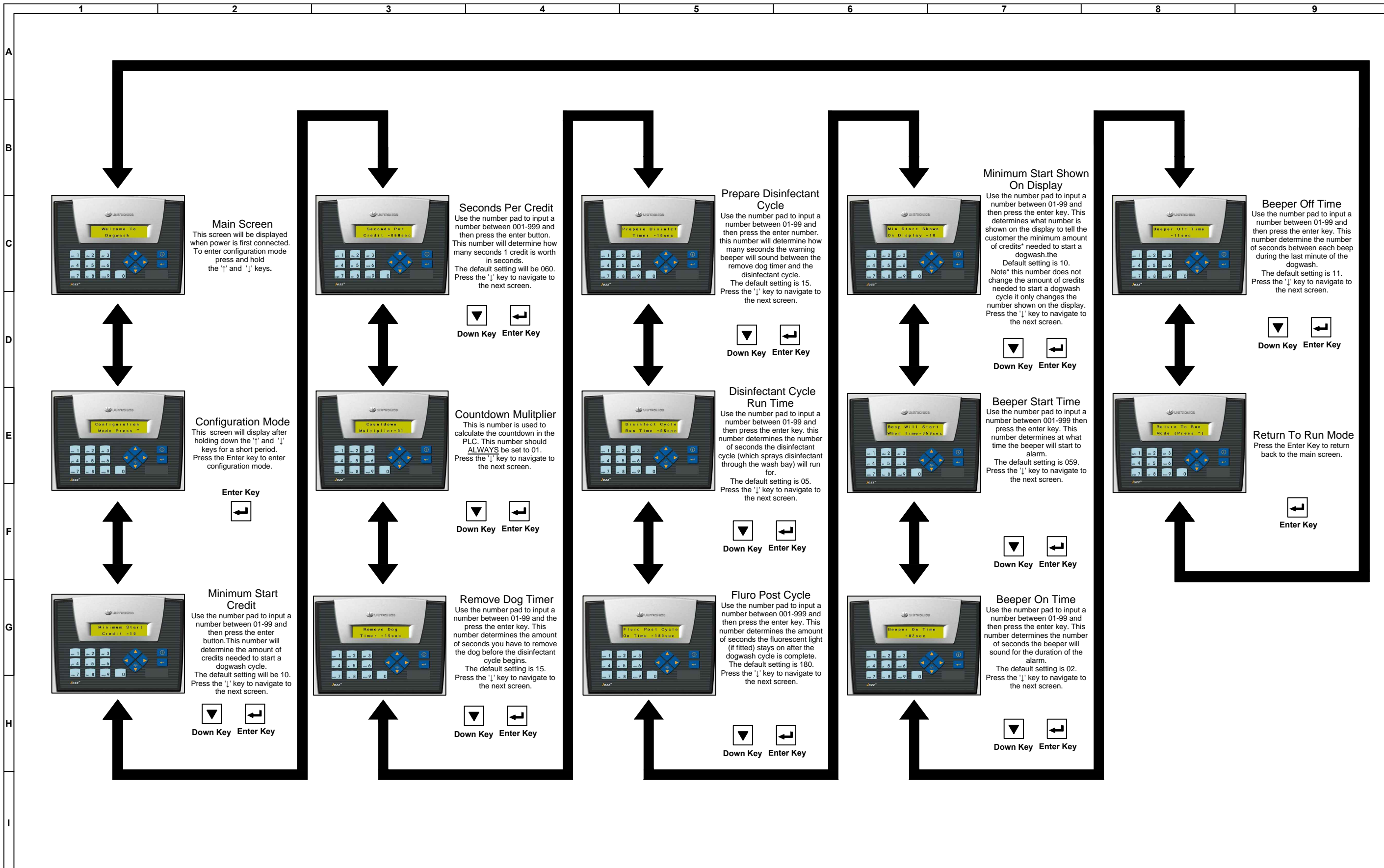

REV	DESCRIPTION	DRAWN	CHECKED	DATE
0	ORIGINAL	A.FERRARO	J.SCHRODER	18/03/2016

THIS DRAWING IS THE SUBJECT OF COPYRIGHT AND MUST NOT BE COPIED OR OTHERWISE USED WITHOUT THE EXPRESS AUTHORITY OF BURKERT CONTROMATIC AUSTRALIA



BURKERT CONTROMATIC AUSTRALIA PTY LTD
 SYDNEY: 15 COLUMBIA WAY, NORWEST BUSINESS PARK, BALUAGRAM HILLS, NSW, 2153
 MELBOURNE: UNIT 11, 26-30 HOWLEYS RD, NOTTING HILL, VIC, 3168
 BRISBANE: UNIT 4, 43 SANDGATE RD, ALBION, QLD, 4010
 PERTH: UNIT 6, 1st FLOOR 85 REED PROMENADE, JOONDALLUP, WA, 6027
 ADELAIDE: INNOVATION HOUSE, FIRST AVE, MAWSON LAKES, SA, 5095

CUSTOMER: WASHTEC AUSTRALIA			A3
TITLE: DOGWASH SEQUENCE OF OPERATION MAIN DISPLAY			
SCALE: N.T.S	JOB N.o. 92150475	SHEET 01 OF 01 SHEETS	REVISION 0

Data Sheet

DHCE 6/50

STIEBEL ELTRON

Technik zum Wohlfühlen

Instantaneous Single Phase Electric Water Heater

Delivers hot water not exceeding 50°Celsius
in accordance with AS3498*



The advantages

- › Electronically controlled to save energy and water
- › Temperature selection up to a maximum of 50°Celsius in accordance with AS3498*
- › No external temperature control device required*
- › Ideal for low flow applications with a switch on flow rate of only 1.5L/min
- › Three selectable temperatures for greater convenience, note that output temperature will be impacted by cold water inlet temperature
 - › ● : 40°C
 - › ●● : 45°C
 - › ●●● : 50°C
- › No flue, ventilation or safe tray required
- › Compact design for space saving installation flexibility
- › Available in electrical size:
 - › DHCE 6/50 - 7.1kW, 30 Amps per phase, single phase 240V
- › WaterMark approved, licence number WMKA21273, AS3498



Ideal installation areas[^]

- › Basin

For more information on the right Stiebel Eltron water heater for your project please contact our Technical Services Department on free call 1800 153 351 (Australia).

*This appliance delivers hot water not exceeding 50°Celsius in accordance with AS3498. Refer to AS/NZS3500.4, local requirements and installation instructions to determine if additional delivery temperature control is required.

[^]Dependent on model selected

Data Sheet

DHCE 6/50

STIEBEL ELTRON

Technik zum Wohlfühlen

Instantaneous Single Phase Electric Water Heater

Delivers hot water not exceeding 50°Celsius
in accordance with AS3498*

SINGLE PHASE ELECTRIC

Model number	DHCE 6/50
Rated output (240V)	7.1kW
Rated current (240V)	30 Amp
Phases	1/N/PE/AC 220..240V
Electrical installation	As per AS/NZS3000
Installation requirements	AS/NZS3500.4.2 & local requirements
Switch on flow rate	1.5 L/min
Permissible operating pressure	1000 kPa
Temperature adjustment	●40°C ●● 45°C ●●● 50°C
IP Rating	IP25
Height	360 mm
Width	200 mm
Depth	110 mm
Weight (filled with water)	2.45 kg
Colour	silver look
Nominal capacity	0.45L
Approvals	WaterMark Lic No. WMKA21273. AS3498

Equipment

For one/several draw off points	Yes/Yes
Heating system	Tubular
Electronic flow rate control	-
Electronic air detection system	-
Accepts pre-heated water (solar)	-
Programmable temperature	-
Wellness shower programs	-
ECO energy & water function	-

Optional accessories

Radio remote control primary	-
Radio remote control secondary	-

Temperature rise chart^

DHCE 6/50

Add the below temperature to the cold water inlet temperature. Temperature will also be dependent on the output dial setting.

4L/min	25°C
6L/min	16°C
8L/min	13°C
10L/min	-
12L/min	-
14L/min	-

^Please note temperature rise is based on connection to 240V.

Our customer support representatives can be contacted on our free call number 1800 153 351 to assist in selecting the appropriate system/systems for your project.

Selecting the right Stiebel Eltron instantaneous water heater

Thank you for considering the Stiebel Eltron instantaneous water heater, with over 90 years of hot water technology experience we are sure you will be happy with your choice of a Stiebel Eltron instantaneous water heater.

The temperature rise table will assist you in determining the appropriate size of instantaneous water heater required for your application. The required temperatures at specific flow rates will determine the size of system needed. Our customer support representatives can be contacted on our free call number 1800 153 351 to assist in selecting the appropriate system/systems for your project.

Installation close to the point of use

The Stiebel Eltron DHCE instant water heaters compact design allows for ease of installation close to the point of use. In order to minimise thermal losses in the pipe work the water heater should be installed as close to the point of use as possible.

Electrical installation

This water heater must be installed in accordance with AS/NZS3000 electrical regulations by a qualified installer.

Plumbing installation

This water heater must be installed in accordance with AS/NZS3500.4.2 and local authority regulations by a qualified installer.

Warranty

For full warranty information please visit www.stiebel.com.au.

Technical Support

Stiebel Eltron (Aust) Pty Ltd
Free Call (Australia): 1800 153 351
Telephone: (03) 9645 1833
Website: stiebel.com.au

DHCE 6/50 instantaneous single phase electric water heater

